



VERTICAL CLOSED TOP AUGER BLENDER

CAPACITY
25 TO 45 TON/M³ PER HOUR

MACHINE SIZE
5,5-7-9-12 TON PER BATCH



7 Ton Vertical Blender

The Vertical Blender is suitable for powder and granular fertilizers production. The machine processes all raw materials into an excellent blend. When the machine has produced a blend, it can be transported to a bag filling station. The clever design makes it possible for the machine to be installed in space-confined areas.

The blending principle of this machine is absolutely unique. A tapering auger is used,

which means that this auger has a width of 101 cm at the bottom and a width of 55 cm at the top. This gives an excellent blending quality. The bottom cone of the blender has a 60-degree angle to eliminate product build-up inside the container. The blender discharges the materials at the bottom using a half-moon Salem valve. A pneumatic cylinder is used

7 Ton Vertical Blender

to open the valve. The blender can be filled with a loader; this loader will fill the hopper with the raw materials. The hopper is located at the side of the blender. A screen inside the hopper catches lumps, wood and all other kind of material that does not belong in the

product. The blend auger transports the materials inside the blender where the actual blending takes place. The blades of this auger are 9 mm thick. The Vertical Blender is constructed of Stainless steel. The top of the blender is closed, however it does contain an inspection gate. The machine stands on 4 support legs and a mild steel scale frame. Beneath each leg a Stainless steel load cell has been mounted. At the top of the blender a gearbox has been mounted. The motor is located beside the blender and is driven by V-belts. The machine contains a digital indicator and a large display.

The Vertical Blender has a capacity of 5,5 - 7 and maximum 9 ton/m³ per batch, with a capacity of 25 to 45 ton/m³ per hour.

This product can be adjusted to customer demands.



9 Ton Vertical Blender with Conveyor





Molenpad 10
1756 EE 't Zand N.H.
The Netherlands

www.e-m-t.nl
emt@e-m-t.nl

Tel.: +31 (0)224 59 12 13
Fax: +31 (0)224 59 14 54

EXAMPLE
VERTICAL & BIG BAG FILLING MACHINE

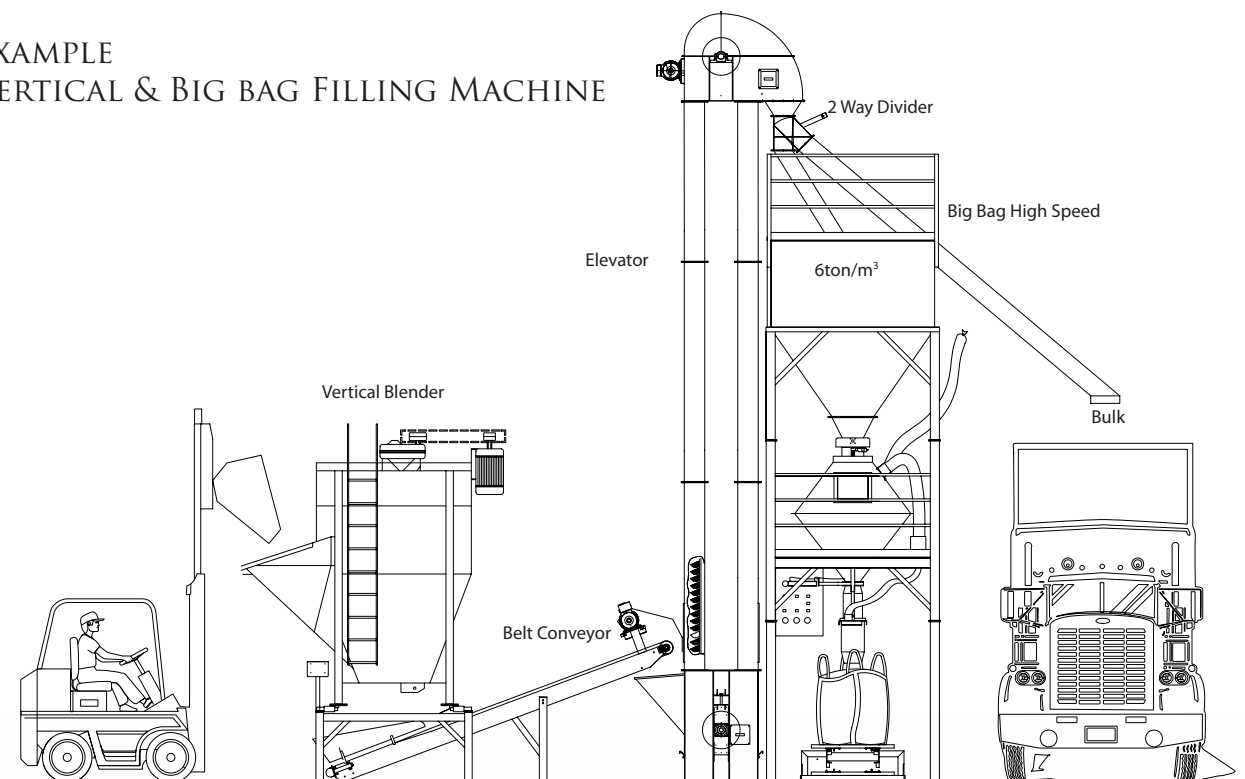

TOP VIEW VERTICAL BLENDER

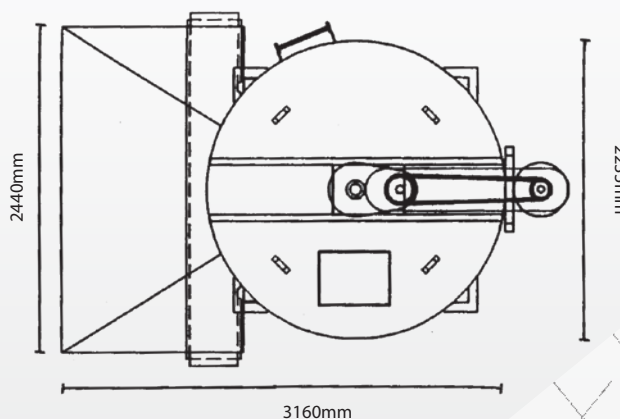

Vertical	5,5- 7- 9 ton/m³
Support Legs Blender	6 mm Stainless steel
Blender body Construction	3 mm Stainless steel
Scale Frame Length	2500 mm
Scale Frame Width	2500 mm
Scale Frame Height	700 mm
Scale Frame	100 x 100 x 4 mm Mild Steel
Scale	Digital 4 Stainless steel load cells and large follow display
Blender diameter	2235 mm
Blender top	Closed Mild/ Stainless steel
Welding	Welded on both sides
Speed blend auger	45 RPM normal steel
Discharging	Bottom of machine
Mild Steel preparing	All mild steel is metal shot blasted
Loadcell cables	Protected in tube
Capacity loadcells	4x 3400= 13600 kg
Paint	Primer Coating + 2 Component Polyamide finishing Coating
Colour	RAL no. 6029 Green
Mixing Time	3 to 4 Minutes
Motor	B3 Feet 1400 RPM, Class F
Installing	On a flat and stable concrete floor
Lump Screen	Mild Steel Intake Hopper
Inspection gate	Stainless steel
Belt Guard	2 mm Stainless steel
Weight/ Density	1 metric ton per 1 m³
Motor resistance	IP 56, extra water and dust closed
Norms	Conform European Norms CE no. 89/392 EEG, Machine directive changed by no. 91/368 EE

Specification	Vertical Blender 5,5 ton	Vertical Blender 7 ton	Vertical Blender 9 ton
Filling Height from intake hopper	2286 mm	2286 mm	2286 mm
Intake hopper width	2440 mm	2440 mm	2440 mm
Overall Height to Top	3685 mm	4115 mm	4572 mm
Empty weight of machine	2025 kg	2250 kg	2610 kg
Content per charge	5,5 Metric ton of fertiliser	7 Metric ton of fertiliser	9 Metric ton of fertiliser
Blending capacity	30 ton per hour	35 ton per hour	45 ton per hour
Mixing Cycle	5 x per Hour	5 x per hour	5 x per hour
Amperage	50Amp.	70 Amp.	85 Amp.

