



KRAUS/ TYLER PADDLE BLENDER

CAPACITY
15-30 TON/M³ PER HOUR FOR KRAUS
30-40 TON/M³ PER HOUR FOR TYLER

MACHINE SIZE
5 TON PER BATCH FOR KRAUS
7 TON PER BATCH FOR TYLER



The Kraus/Tyler Blender is suitable for powder and granular fertilizers production. The machine processes all raw materials into an excellent blend. When the machine has produced a blend it can be transported to a bag filling station. The Stainless steel Kraus-Tyler Paddle Blender must be filled from the top with a loader. A steel screen that catches lumps has been mounted on top of the machine. A forklift can remove this screen. The blender has a steel-stirring arm on which paddles are connected. A chain

blender unit stands on 4 load cells with a digital indicator and a large display. The discharge gate is located at the middle of the machine. The blender is standing on a mild steel framework.

The blending content of the Kraus Blender is 5 metric ton. The capacity is 15 to 30 ton/m³ per hour. The blending content of the Tyler Blender is 7 metric ton. The capacity is 30 to 40 ton/m³ per hour. This product can be adjusted to customer demands.



drives the stir arm. The stir arm inside the machine moves the material to the discharge gate when the machine is unloading. The number of rotations of this arm is 5 times per minute. The blending process takes 3 minutes. A motor with gearbox drives the stir arm. The whole





Molenpad 10
1756 EE 't Zand N.H.
The Netherlands

www.e-m-t.nl
emt@e-m-t.nl

Tel.: +31 (0)224 59 12 13
Fax: +31 (0)224 59 14 54

EXAMPLE
KRAUS/TYLER
BIG BAG FILLING MACHINE

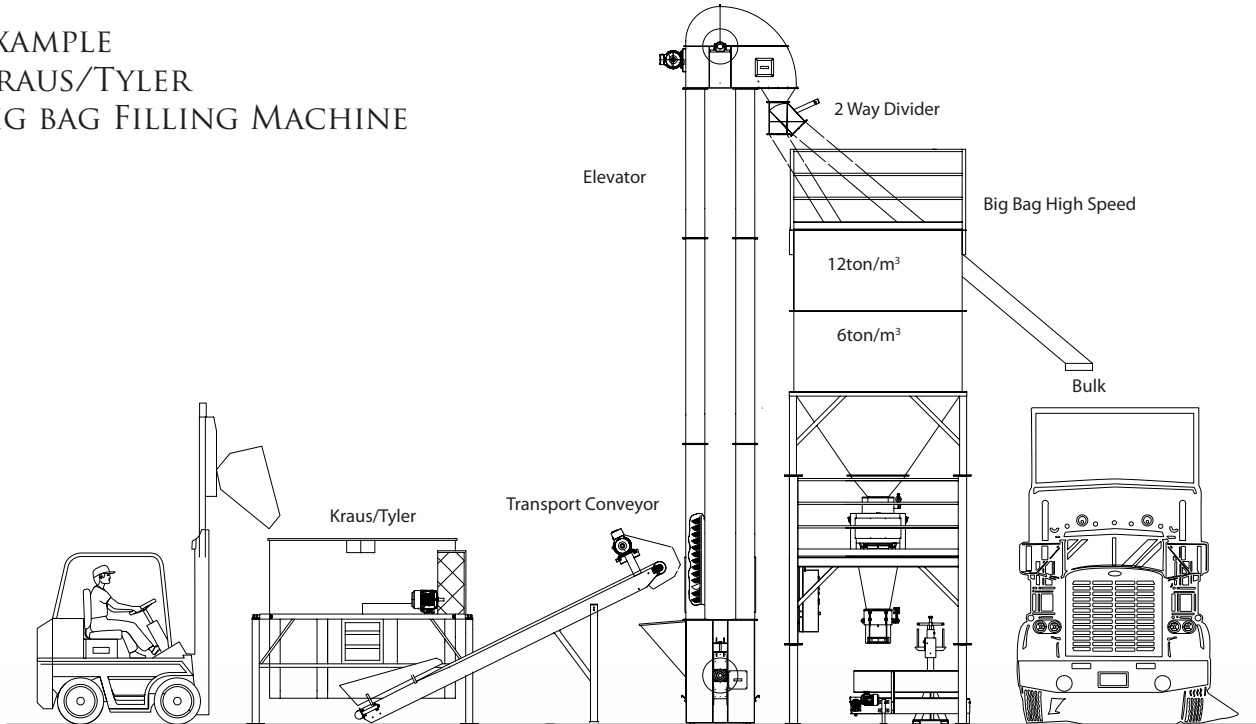

EXAMPLE
KRAUS/TYLER BLENDER

Kraus/ Tyler	5- 7 ton/m³
Blender body construction	4mm Stainless steel
Inspection	From Top
Blender Shaft	120x 120mm Mild Steel
Blending method	Paddle Blender
Paddle Construction	Mild Steel
Paddle Length	600mm
Scale Frame	100 x 100 x 4mm Mild Steel
Lump Screen	On top of Hopper Mild Steel
Scale	Digital 4 Stainless steel load cells and large follow display
Blender top	Open
Hopper Screen	Mild steel expanded metal
Welding	Welded on both sides
Speed mix paddle auger	5 RPM normal steel
Discharging	Bottom of machine
Steel preparing	All mild steel is metal shot blasted
Loadcell cables	Protected in tube
Capacity loadcells	4x 3400= 13600 kg
Paint	Primer Coating + 2 Component Polyamide finishing Coating
Colour	RAL no. 6029 Green
Mixing Time	3 to 4 Minutes
Motor	B3 Feet 1400 RPM, Class F
Motor resistance	IP 56, extra water and dust closed
Installing	Flat and stable concrete floor
Norms	Conform European Norms CE no. 89/392 EEG, Machine directive changed by no. 91/368 EE

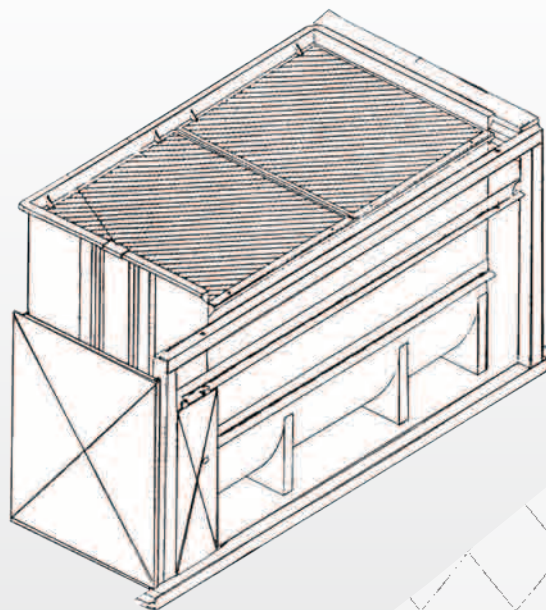

Kraus/ Tyler Blender	5 Ton	7 Ton
Filling Height	2770 mm	3000 mm
Blender Body width	1650 mm	2440 mm
Blender Body length	2560 mm	4240 mm
Weight of the machine empty	3000 mm	4000 mm
Content per change	5 metric ton of fertilizer	7 metric ton of fertilizer
Blending capacity	15-30 Ton	30-40 Ton
Motor	22Kw 400V 50 Hz	32Kw 400V 50 Hz
Amperage	50 Amp	70A mp

