



ECONOMIC/ LOW PROFILE FIBC/ BIG BAG FILLING MACHINE

CAPACITY:
100 KG TO 1250 KG BAGS
30-40 TON/M³ PER HOUR
60 BAGS PER HOUR



Low Profile
FIBC/ Big Bag Machine

The big bag Low Profile and Economic are constructed to fill FIBC bags (Flexible, Intermediary, Bulk, Containers). The machine automatically weighs and fills bags of 100 to 1250 kg. This machine is suitable for powder and granular materials. The Storage Hopper stands on 4 H-profile legs. The materials are put into the storage hopper. A pneumatic valve has been mounted under the storage hopper. This valve has a large and a fine opening. The hopper unloads into a Stainless steel pipe that fits into a big bag. The big bag is standing on a platform scale on the floor. The height of the filling pipe is adjustable over a length of 400 mm. The big bag must be held up and manually closed around the filling pipe. By using this system, no dust comes free during the filling process. Before the filling process starts, a blower will blow air into the bag. When the bag has its full size, the materials flow

into the bag. The loadcell platform scale will determine the weight of the product. When the bag is full, a roller conveyor transports the Bag. The scale system works with a weigh indicator of Avery Salter Weightronix. The whole unit can be operated automatic or manual. The unit operates with pneumatic Stainless steel and Fibreglas cylinders. The machine is available in different set up possibilities. The Big bag economic is a fixed machine with a storage hopper above it. The Big bag low profile is a portable machine that can be moved with a forklift. It can be filled with a loader directly into the hopper. The capacities of both systems are 30 ton per hour with big bags of 1000 kg and approx. 50 bags of 500 kg per hour. This product can be adjusted to customer demands.



Economic
FIBC/ big bag Machine





Molenpad 10
1756 EE 't Zand N.H.
The Netherlands

www.e-m-t.nl
emt@e-m-t.nl

Tel.: +31 (0)224 59 12 13
Fax: +31 (0)224 59 14 54

**EXAMPLE
VERTICAL BLENDER & ECONOMIC
FIBC/ BIG BAG FILLING MACHINE**

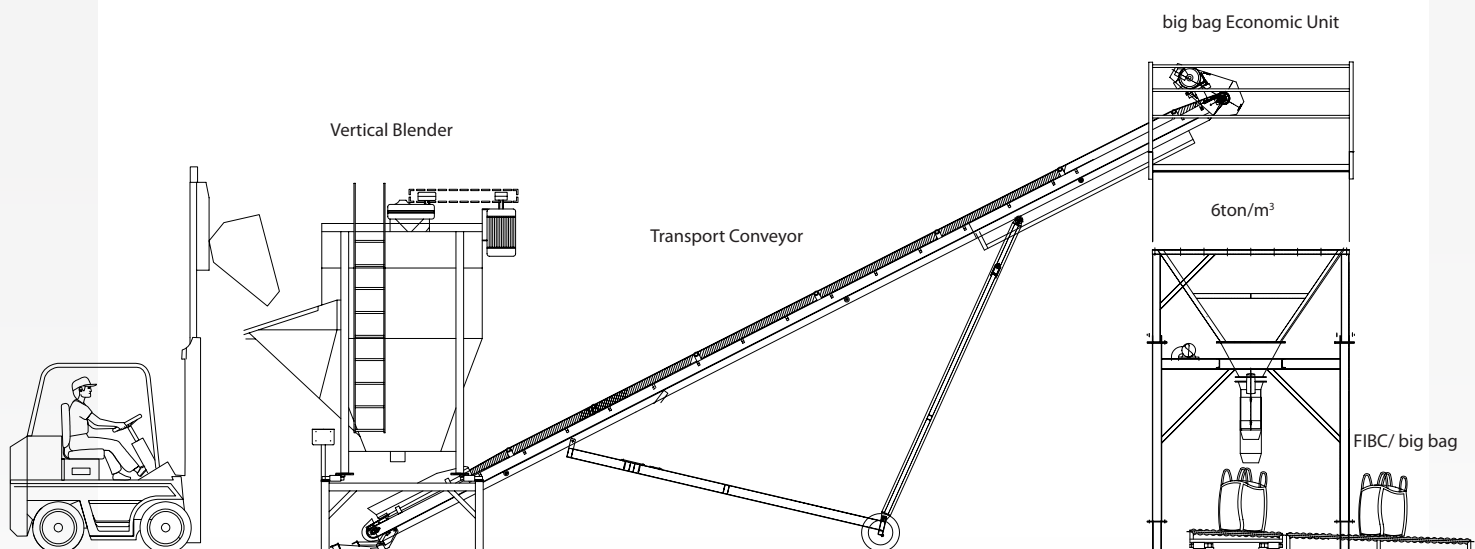

**EXAMPLE
FORKLIFT & LOW PROFILE
FIBC/ BIG BAG FILLING MACHINE**

FIBC/ big bag	Low Profile & Economic
Frame	Mild Steel HEA120
Capacity per hour	25 Ton per hour 30 Ton per hour
Scales	Floor Platform
Pneumatic cilinders	Stainless steel anf Fiberglass
Fill pipe	Stainless steel
Discharge Bags	Roller Conveyor
Filter System	Dust Bag Filter
Power Supply	380 Volt-20 Amp-50Hz-3Phase
Type Bags	FIBC Big bags
Capacity Bags	200 - 1200kg
Colour	RAL 6029 Green
Frame Profile	100 x 100x 4 mm
Machine operating	Electric Pneumatic
Scale	Digital 4 Stainless steel load cells and large follow display
Weight/ Density	1 metric ton per 1 m3
Calibratable	Automatically
Installing	On a flat and stable concrete floor
Welding	Welded on both sides
Blower	2x Blower
Steel prepairing	All mild steel is metal shot blasted
Loadcell cables	Protected in tube
Capacity loadcells	2x 200 kg
Weight & Measure	T5582
Paint	Primer Coating + 2 Component Polyamide finishing Coating
Norms	Conform European Norms CE no. 89/392 EEG, Machine directive changed by no. 91/368 EE

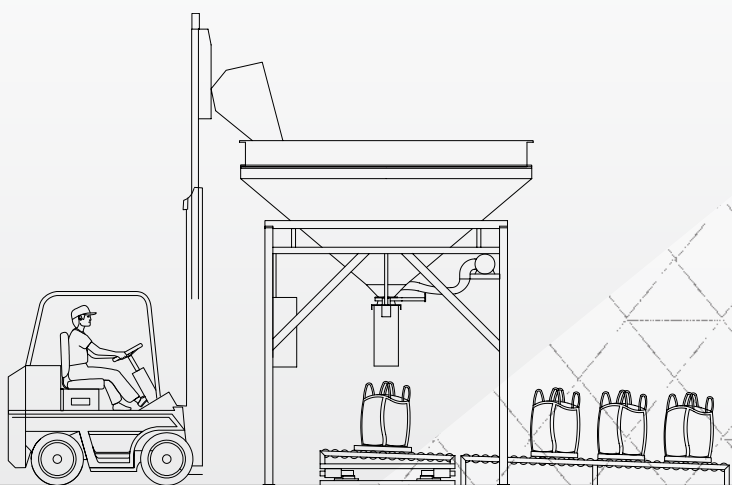

Specifications	Low Profile	Economic
Total Height	3590mm	4574mm
Capacity Hopper	3-7 ton/m³	6-12 ton/m³
Total Weight	2100kg	3000kg
Filling Height	3590mm	4574
Hopper Width	3600mm	2300mm
Hopper Lenght	2280mm	2280mm
Roller Conveygr lenght	4000mm	4000mm

